

The intent of this document is to clarify certain unclear aspects in the rules and the policies on them for Formula Student Netherlands. If applicable, this document supersedes the FSG 2023 rules for FSN 2023.

If any question arises through this document, do not hesitate to contact FSN for clarification.

T1.1.10 & T 3.10.6 Node to node triangulations.

- The attachment of the rear wing to the Main Hoop Bracings is NOT allowed without additional support. Node to node triangulation must be applied to provide an adequate load path and avoid implementing loads to the Main Hoop bracing tubes. The already existing nodes of the Main Hoop Bracings – Main Hoop connection and the Main hoop bracing – Main Hoop Bracings’ support connection can be used. If these nodes are not used, a proper triangulating tube must support the Main Hoop Bracings. The distance between the tubes’ centerlines and the nodes must not be greater than 50mm.

Head restraint attachments do not need to be triangulated, but they must still comply with the specified rule loads.

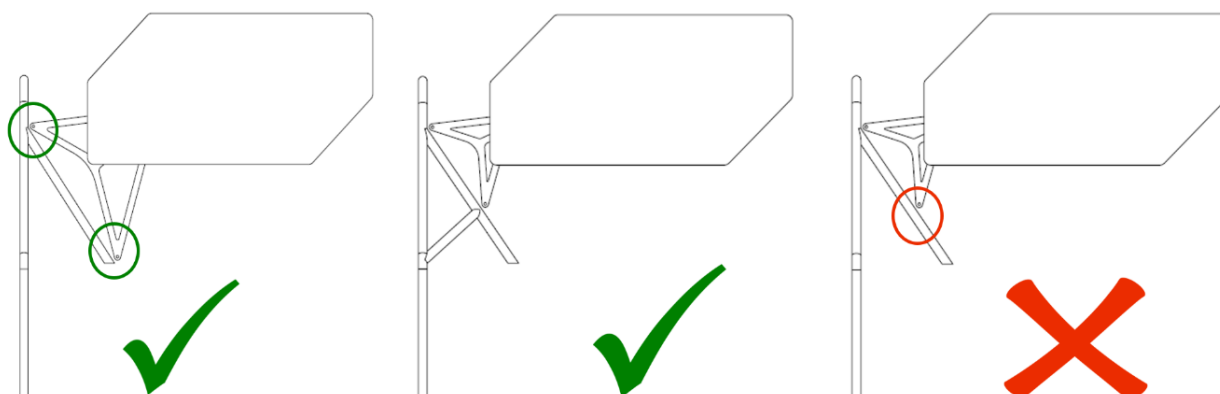

Figure 1 Schematic of wing attachment triangulation.

- Triangulation that fulfills the mentioned criteria is also required for the **lower harness attachment points**.

SES - General

If any tab of the SES shows as passed due to all cells being “green”, additional equivalency can still be requested if the used method of equivalency is not sufficient.

Any attachment between primary structure components must show equivalency to T3.16.1 in the SES.

Experiments' Remarks

T4.5.5 Driver's Harness Experiments

The representative test panels including the harness attachments, bracket and eyebolt or tab must be **the same harness attachment & construction** as the one used in the car.

Different harness attachments (especially stronger and or stiffer) used in contrast with the actual attachment are not acceptable to prove structural rigidity of the harness attachment.

T3.5 Laminate Testing - Experiment Panels

Each team must show ALL panels (including complete IA + FBH representatives if applicable) that correspond to each area of the Monocoque structure, as defined by the SES.

T 7.2.7 Hot liquids circulation components

Catch cans, their mountings, and all cooling or engine lubrication system hoses and **hose clamps** must be compliant to rule T7.2.7

This is also applicable for the following cooling circuits:

- Engine cooling circuit.
- Electric drive cooling circuit.
- Accumulator cooling circuit.
- All other circuits containing hot liquids.

Circuits without a pressure relief must have an over-temperature protection system, which must be shown/documentated at scrutineering.

Clamping methods that can damage the cooling hoses are not allowed, e.g. safety wire

T 2.2 & T 8.2 Aerodynamic Devices & ground clearance

T 8.2.4

All restrictions must be fulfilled with the wheels pointing straight and **with any used suspension setup** with and without a driver seated in the vehicle. If a driver is used for an event, the car should be compliant with that driver for that event.

This also applies to the Pre and Post- Inspections during the Dynamic disciplines. Team members have to make sure that the car is compliant in any state that it is going to be checked (especially after driver change in Endurance).

T 10.2 Securing Fasteners – Nylon Locknuts

T 10.2.2

The following **methods are accepted** as positive locking mechanisms:

- Nylon lock nuts (ISO 7040, ISO 10512, EN 1663 or equivalent) **for low temperature locations (80 °C or less).**

The use of nylon lock nuts in the in-wheel assembly is allowed, given that there has to be a minimum of 50 mm distance between brake components and the nylon lock nut as well as that the locknut is not used to fasten any brake parts. Lock nuts used for wheel fastening are accepted as long as they are in pristine condition. The same applies to nylon lock nuts located near the exhaust, engine or any other significant heat source.

T 2.5 Wheels

T 2.5.1

The use of safety wiring as positive locking in center wheel nuts is considered insufficient to prevent loosening and is thus not allowed. Proper industrially manufactured cotter pins, center lock wheel springs or mechanisms compliant with T 10.2 should be used.

T 2.5.2 Studs

The assembly must be positively locked and be a mechanical connection (green example).

Wheel studs may not be fastened/locked by friction only, e.g. a press fit (red example).

Threaded studs are allowed as long as it is positively locked.

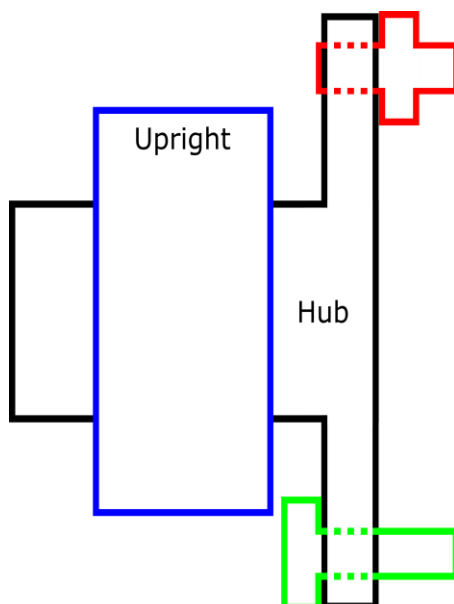

Figure 2 Schematic of studs

T10.2 Locking

Wheel nuts must comply with **T 10.2**. An exception is made for commercially designed fasteners designated for wheels. In this case documentation must be presented together with proof of purchase, datasheets, calculations, proof of correct installment and other necessary documentation needed to prove their compliance.

Helmet protection

Main hoop shutdown buttons cannot come into contact with the driver.

Any helmet must not be able to hit any hard object or safety critical electrical component.

IN 12 Fluids & scrutineering

Teams are responsible to fill up the necessary fluids **before weighing** at the Mechanical Inspection. In case the fluids are not filled, problems are caused during the Dynamic Post Inspection due to the weight difference.

NOTE: Fuel inside the main Mechanical Tent **IS NOT ALLOWED**.

- The cars must be in a pristine condition when entering the Technical Inspection. Accommodated liquids (brake fluid etc.) anywhere inside the car must be wiped dry. Failure to do so may cause the car to be deemed “not ready to race” and can be sent out of the queue.

Mounting of timekeeping devices

Mounting of timekeeping devices is specified in the competition handbook.

Monocoque manufacturing quality

Monocoques should be manufactured according to the test panels presented in the SES.

Structurally significant manufacturing errors, delamination or dry spots are not allowed.

Rollover envelope

No part of the driver may be outside of the rollover envelope in any orientation/view. In a ready to race state, the elbows of the drivers must be inside the rollover envelope.