



Arrival Information & Directions

The TT Circuit is located south of the city of Assen, next to E232/A28 motorway. It is a vast complex with many entrances.

Upon arrival, all teams must proceed to the “Arrival Point”

Link: <https://goo.gl/maps/ChLYuRdZoeRyTjLJ8>

Coordinates: (52°57'59.8"N 6°32'01.9"E)

Please read this instructions carefully.

Route from the **North** (Groningen) E232/A28 motorway:

1. Exit the motorway at Exit 31a – Assen Zuid (TT Circuit)
2. Take the first exit on the roundabout “Eysinkweg”
3. Take the second exit on the next roundabout to continue on ‘Eysinkweg’
4. Take a right turn at the crossing “Eysinkweg – De Haar”
5. Take the third exit on the left on “De Haar” (Don’t drive under any large orange TT signs). This exit is next to the bus stop.
6. You have arrived at the Arrival Point

Route from the **South** (Emmen/Zwolle/Hoogeveen) E232/A28 Motorway

1. Exit the motorway at Exit 31a – Assen Zuid (TT Circuit)
2. Take the third exit on the roundabout (overpass over the motorway)
3. Take the first exit on the next roundabout “Eysinkweg”
4. Take a right turn at the crossing “Eysinkweg – De Haar”
5. Take the third exit on the left on “De Haar” (Don’t drive under any large orange TT signs). This exit is next to the bus stop.
6. You have arrived at the Arrival Point

Route from the **East** (Veendam/Gieten) N33 Autoroute

1. Exit the Autoroute at exit 32 – Assen
2. Take the second exit (left) on the roundabout “De Haar”
3. Take the third exit to your right on “De Haar” , the exit is just after the bus stop
4. You have arrived at the Arrival Point

Arrival Point Opening Times (all times CEST):

Friday July 2nd 2021: 18:00-20:00

Saturday July 3rd 2021: 08:00-23:00

Sunday July 4th 2021: 08:00-18:00

(map on the next page)



Arrival Procedure: COVID Testing, Entering the Campsite & Unloading

Upon arrival at the Arrival Point, the team will be tested for COVID via a self-test. The self-test is provided by the organization.

After 15-30 minutes, the self-test results will be checked by the organization. If the team returns negative tests, the team will be guided to the campsite. If the team tests positive, a second test may be taken to avoid false-positives. If the second test also returns positive, the team may be excluded from the competition site until the team can return a negative test for all members.

Entering the campsite may be delayed by the organization to avoid overcrowded areas. Placement of the team on the campsite is done via allocation by the organization, a team cannot freely choose their spot (no first-come-first-serve)

After unloading, the team truck/trailer must return to the arrival point and be parked there. The parking area is secured. Smaller vans/people carriers can be parked close to the campsite on instructions of the organization. When the paddock and pit garages open on Sunday at 19:00, the team vehicles including trailers may be parked in the paddock.

Registering the Team

The TT Education Centre functions as campsite office during the arrival weekend. Once arrived on the campsite, the team manager must register the team and collect documents.

What the team should bring to registration:

- Team Manager (no team members)
- Printed and filled in copies of the [Waiver of Liability \(click to download\)](#) for each team member
- Printed copies of the front – and backside of the team driver's drivers licenses

Entering and leaving the camp site during the event

A team is free to leave the camp site between 07:00 and 22:00 on any day. Team members do not have to be re-tested after leaving the camp site. All teams are advised to limit their exposure as much as possible.

Access to the Paddock and Pit Garages

General access to the paddock and pit garages will commence on Sunday July 4th at 19:00. No team member is allowed to access the paddock before that time, except for the teams that have been selected for early scrutineering on Saturday July 4th :

Teams 395, 181, 313, 132, 675, 112, E31, E99, E90, E77, E40, E33, E59 may enter the paddock with a truck and trailer and 4 team members on Saturday July 3rd at 11:45. These teams must leave the paddock by 18:30 and return their vehicles to the arrival point. No pit garages are available on Saturday.

All other teams will have access to the paddock from Sunday July 4th at 19:00

Pit garages are shared by two teams each. One team is located on the "Pit Lane" side and one team is located on the "Paddock" side of the pit garage. The dimensions of the pit garages can be found in the drawing on the next page.

Pit Lane

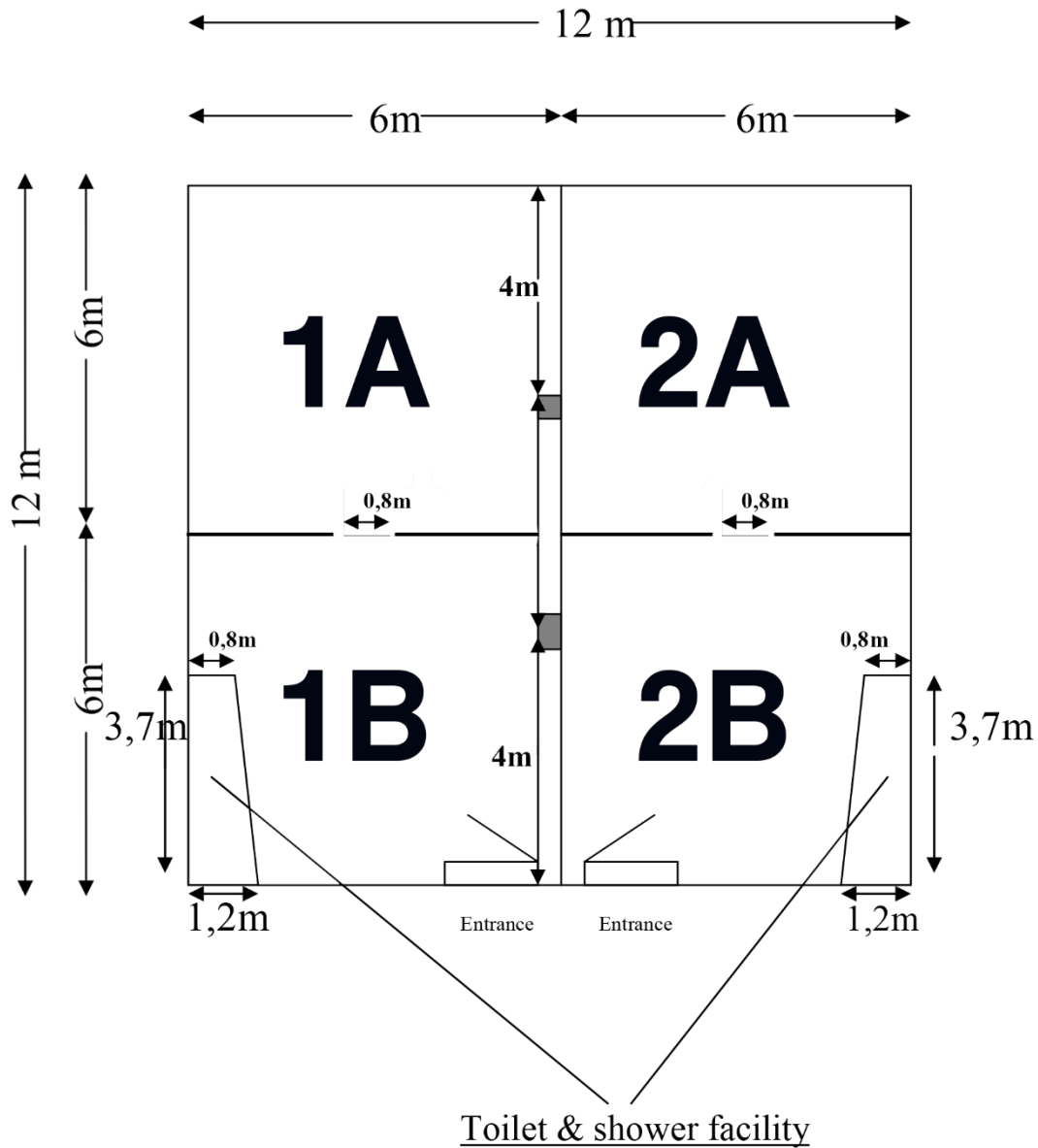

WiFi is available in each garage, the password is located on a notice board inside the pit garage.

The team on the Paddock (B) side should leave a small entrance (min 0.8m) for the team on the Pitlane (A) side to access their side of the pit garage.

The 2021 Pit Garage allocation can be found in the table on the next page.

Car	University	Pit Garage
110	AGH Krakow	29-PIT
111	TU Wroclaw	11-PAD
112	UAS Kempten	23-PAD
125	UPC Manresa	27-PAD
132	Democritus Uni Thrace	11-PIT
149	Uni Erlangen	25-PAD
157	ENIM Metz	24-PIT
158	Uni Paderborn	15-PAD
161	UFV Madrid	25-PIT
174	TU Brno	06-PIT
181	EC Lyon	30-PIT
194	TU Budapest	19-PIT
218	Uni Seville	14-PAD
221	UAS Graz	07-PAD
229	Uni Stuttgart	10-PAD
235	Uni Maribor	31-PAD
246	UAS Arnhem	21-PIT
248	Uni Bochum	17-PIT
270	UAS Coburg	22-PIT
291	Uni Lund	19-PAD
296	Uni Rey Juan Carlos	31-PIT
300	TU Rzeszow	26-PIT
313	TU Berlin	13-PAD
360	UAS Ravensburg-Wein	12-PIT
373	UC3M Leganés	28-PIT
395	TU Valencia	03-PIT
522	Uni Napoli	29-PAD
675	UAS Stralsund	21-PAD
E03	UAS Munich	07-PIT
E10	UAS Augsburg	05-PIT
E12	UPC Terrassa	23-PIT
E13	TU Berlin	13-PIT
E22	KU Leuven	17-PAD
E25	NTU Athens	20-PIT
E28	Uni Kassel	27-PIT
E31	TU Munich	03-PAD
E33	ETH Zürich	20-PAD
E40	TU Eindhoven	06-PAD
E41	TU Wien	24-PAD
E42	TU Darmstadt	10-PIT
E44	Deggendorf IT	26-PAD
E45	UAS Sankt Augustin	12-PAD
E51	Uni Seville	14-PIT
E53	Uni Siegen	28-PAD
E54	Uni Zagreb	16-PIT
E56	Tecnun Uni Navarra	22-PAD
E57	UPC Barcelona	08-PIT
E58	Uni Paderborn	15-PIT
E59	TU Dresden	08-PAD
E60	UAS Nuremberg	32-PIT
E61	UAS Aalen	32-PAD
E64	TU + UAS Kaiserslauter	09-PIT
E71	TU Ilmenau	30-PAD
E76	TU Freiberg	04-PAD
E77	DHBW Stuttgart	05-PAD
E85	TU Delft	09-PAD
E90	PT Milano	04-PIT
E99	RWTH Aachen	16-PAD

